

OPERATOR'S MANUAL

Brush Crusher™

BC-4200

BC-4215



**Specialists in Quality and
Time Saving Farm Equipment**

ONLINE ATTACHMENT CATALOG at: www.loaders.com

READ AND SAVE THIS BOOK

A product of Westendorf Manufacturing Co., Inc.

WESTENDORF MFG. CO., INC. • ONAWA, IA 51040 • 712.423.2762 • www.loaders.com

SECTION 1: INTRODUCTION

Welcome To The Westendorf Family

Your new Westendorf equipment is the highest quality and time saving machinery available. We urge you to exercise sound judgement in the operation and maintenance of this equipment to assure long, trouble-free use and personal safety. It is important to read this manual thoroughly and understand it completely before assembly or operation of this equipment.

This manual should be considered a permanent part of your equipment and be transferred to the new owner if the equipment is sold. It consists of instructions and guides for operating your new equipment. It should be your first, not last resort when dealing with questions.

Thank you for your purchase of our product. If there is anything further we can do to assure complete satisfaction, contact your Westendorf dealer. If you still need help, please call on us. We will be glad to assist you in any way we can.

Thank You;
Westendorf Manufacturing

Terminology

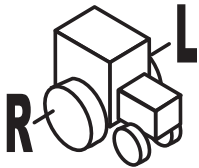

Basic terminology that is used throughout this manual has been identified in the illustration below. Components and instructions in this manual are identified as "left" or "right". This is determined as sitting "in the operators seat facing in the normal direction of travel". See figure.

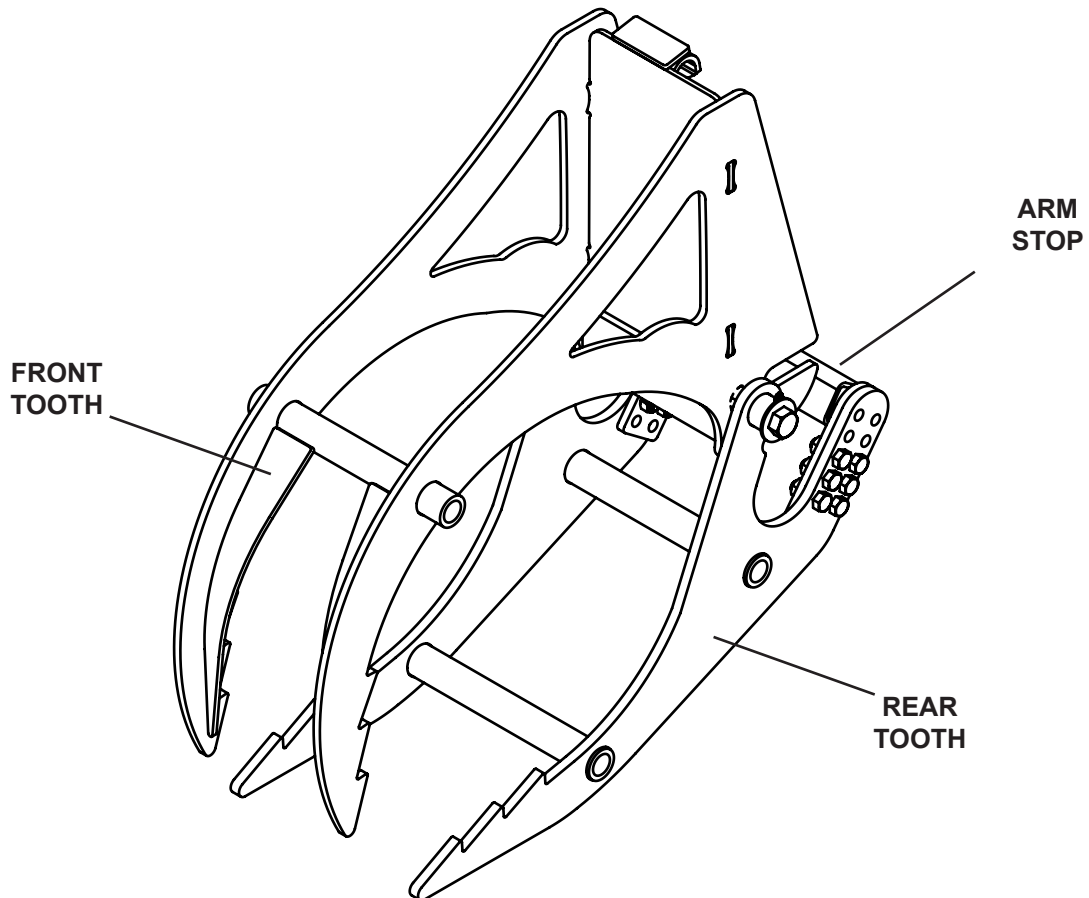

SECTION 1: CONTENTS

Section 1 - Introduction

Welcome to the Westendorf Family	2
Terminology	2
Table of Contents	3
Serial Number Location	4
Dealer Preparation Checklist	4
Limited Lifetime Warranty	4-5

Section 2 - Safety

Recognize Safety Information	6
Safety Alert and Signal Words	6
Safety Instructions	6
Tractor Requirements	6
Maintenance and Inspection	6
Prepare For Emergencies	7
Do Not Allow Riders	7
High Lift Loaders	7
Avoid Rollover	7
Avoid Power Lines and Underground Utilities	7
Lower Operating Speed	7
Replace Safety Signs	7
Prevent Falling Loads	8
Transport Loads Safely	8
Raised Loader	8
Avoid High Pressure Fluids	8
Hydraulic Control Functions	8
Ballast and Tread Settings	
Determination of Ballast	9
Minimum Tread Settings	9
Round Bale Safety	10
Balance Uneven Loads Properly	10
Handling Your Brush Crusher	10
Using Your Brush Crusher & Safety Decal Locations	10

Section 3 - Mounting / Dismounting And Attachments

Mounting and Dismounting	11
Approved Attachments	12

Section 4 - Operation

The Mechanical Advantage	13
Approaching the Load	13

Section 5 - Service & Maintenance

Maintenance Checklist	14
Lubrication	14
Torque Charts	15
Parts	16
Assembly Instructions	17
Preparing the Brush Crusher™ for Storage	18
Storing the Brush Crusher™	18

Prop. 65 Warning for California Residents



WARNING: This product may contain chemicals known to the State of California to cause cancer, birth defects, or other reproductive harm.

SECTION 1: WARRANTY & REGISTRATION

Figure illustrates the product serial number location.

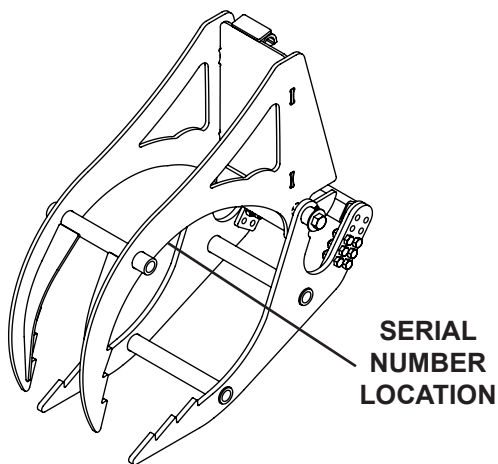

The following information is needed for service and parts.

Product Serial Number: _____

Model Number: _____

Customer Name: _____

Address: _____

City: _____ **State:** _____ **Zip:** _____

Date Of Purchase: _____

Tractor Make And Model: _____

Dealer Preparation Checklist

Before delivering machine, the dealer must complete the following checklist and sign, along with the customer where noted below. After completion, copy this page and fax to Westendorf Manufacturing Co. Inc. at 712-423-1460.

Do not remove this page from manual.

- Machine is properly assembled.
- All safety decals in proper location and legible.
- All hardware tightened to specification. See torque chart in Service and Maintenance section.
- Customer has correct mounting kit for loader and tractor.
- Customer has appropriate attachments for loader operations (buckets for loose materials, bale spear for round bales; forks for palletized material, etc.).
- Machine operates properly.
- Operator's manual has been delivered to the owner/operator and that person has been instructed on the safe and proper use of the loader.

Customer's Signature

Dealer's Signature

⚠ WARNING CRUSHING HAZARD.

The tractor must be equipped with a ROPS or ROPS Cab, and seat belt be used for all loader operations.

Limited Warranty

Westendorf Manufacturing Co., Inc. warrants to the original purchaser only, all new Westendorf equipment to be free from defects in material and workmanship under normal use and service. Westendorf Manufacturing Co., Inc. will repair or replace any defective part manufactured by Westendorf Manufacturing Co., Inc. and returned to Westendorf Manufacturing Co., Inc. at Onawa, Iowa (shipping costs prepaid), within one year from the original date of purchase of the equipment covered by this agreement. Other parts furnished by dealers or other manufacturers for resale or assembly are subject to the warranty of the other manufacturers only. These warranties are valid only if the equipment has been used and maintained in accordance with normal equipment maintenance and service.

The limited warranty of the above paragraph applies to cylinder packings for a period of ninety (90) days.

Westendorf Manufacturing Co., Inc. does not warrant in any matter, including fitness for a particular purpose, parts or equipment purchased from other manufacturers. Although the Westendorf loader is designed to minimize tractor strain, the manufacturer will assume no responsibility for damage to tractors or any other equipment.

The warranties given herein are given in lieu of all other warranties, expressed or implied, including without limitation, the warranty of merchantability and the warranty of suitability for a particular purpose. It is agreed that the buyer's sole remedy shall be limited to repair or replacement of defective parts as described above for any breach of warranties. It is expressly agreed that Westendorf Manufacturing Co., Inc. assumes no liability for any consequential damages arising out of a breach of this contract or any warranties arising therefrom.

Westendorf Manufacturing Co., Inc. will not be liable for commitments or agreements or warranties made by any of its employees, agents or dealers not in accordance with the above warranty.

No warranties, expressed or implied, of fitness or merchantability are made or arise with respect to used equipment.

Basic terminology is used throughout this manual. Figure on preceding page identifies the different parts of the loader and their terminology.

SECTION 1: WARRANTY & REGISTRATION

After completion, copy this page and

MAIL: Westendorf Mfg.Co., Inc.
PO Box 29
Onawa, IA 51040

FAX: (712) 423-1460

EMAIL: internetsales@westendorfmfg.com

OR Register Online Now
www.loaders.com
(Click on My Westendorf)

PLEASE PRINT CLEARLY. THANK YOU

THIS CARD REGISTERS YOU AS AN OWNER OF WESTENDORF EQUIPMENT

Name _____
Address _____
City _____ State _____ ZIP _____
Phone _____
Email _____
Dealer's Name _____
Dealer's City _____
Date Purchased _____
Product Purchased _____
(i.e. loader, attachment, etc.)
Model# _____
Serial# _____
Registration completed by: Kit# _____
 Customer Dealer Order# _____

Tell Your Friends About Us...

List three valid referrals to receive a **FREE** gift from Westendorf!

1) Name _____
Address _____
City _____ ST _____ ZIP _____
Phone _____
Email _____
2) Name _____
Address _____
City _____ ST _____ ZIP _____
Phone _____
Email _____
3) Name _____
Address _____
City _____ ST _____ ZIP _____
Phone _____
Email _____

PLEASE TAKE A MINUTE TO TELL US HOW WE DID

TELEPHONE SERVICE	YES	NO	N/A	COMMENTS
Was the person who took your order courteous & prompt?				
Did you receive all the technical information requirements?				
Were you informed of additional merchandise offered?				
Were you given all the delivery details?				

ORDER SHIPPING/FOLLOW-UP	YES	NO	N/A	COMMENTS
Did your order arrive complete & in good order?				
Was your order packed properly & without damage?				
Did your invoice arrive correctly?				
Were all assembly instructions & manuals packed w/order?				
Did all necessary parts arrive with order?				

Please fill out:	SUPER	GOOD	POOR	N/A	SUGGESTIONS
Customer service overall					
Shipping and crating					
Product appearance					
Product design and function					
Manuals & assembly instructions					
Accounts receivable					

OVERALL EXPERIENCE: EXCELLENT GOOD SATISFACTORY FAIR POOR

SECTION 2: SAFETY

Recognize Safety Information

This is the safety alert symbol. This symbol identifies important safety messages on your machinery and in this manual. When you see this symbol, be alert to the possibility of personal injury.

Carefully follow the recommended precautions and safe operating practices.



Safety Alert Symbol And Signal Words

This manual provides instructions for the operation and care of your Westendorf product. The instructions in this manual must be followed to ensure the safety of persons and satisfactory life of the implement. Safety precautions to protect against injury or property damage must be followed at all times.

You must read, understand, and follow the instructions given by the tractor manufacturer, as well as the instructions in this manual.

The safety information in this manual is denoted by the safety alert symbol: 

The level of risk is indicated by the following signal words:

 **DANGER** *White letters on RED*

DANGER indicates a hazardous situation which, if not avoided, will result in death or serious injury.

 **WARNING** *Black letters on ORANGE*

WARNING indicates a hazardous situation which, if not avoided, could result in death or serious injury.

 **CAUTION** *Black letters on YELLOW*

CAUTION indicates a hazardous situation which, if not avoided, may result in minor or moderate injury.

NOTICE *White letters on BLUE*

NOTICE indicates a property damage message.

Safety Instructions

Carefully read all safety messages in this manual and on equipment safety signs. Keep safety signs in good condition and replace missing or damaged safety signs. New equipment components and repair parts must include the current safety decal. Safety decals are available at no charge from your Westendorf dealer.

Learn how to properly operate equipment. **NEVER** allow anyone to operate equipment without proper instruction, while fatigued, or under the influence of alcohol, prescription or non-prescription medication.

Keep equipment in proper working condition. Unauthorized modifications to the equipment may impair the function, or more importantly, have an effect on your safety.

Know the regulations and laws that apply to you and your industry. This manual is not to replace any of them. Additional information may be found on the world wide web at: www.asae.org or www.osha.gov.

If you do not understand any part of this manual, contact your Westendorf dealer.

Tractor Requirements

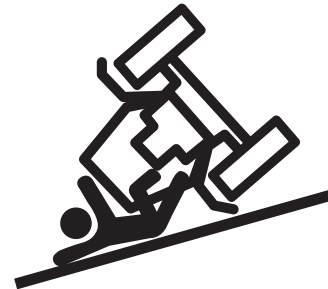

Narrow front end tractors can be unstable when equipped with a front end loader and can rollover. Use extreme caution when operating a narrow front end tractor equipped with a loader.

Operate on level ground only, keep loads low and avoid sharp turns.

Mount loader on a tractor equipped with wide front end and a ROPS or ROPS Cab.

Tractor seat belt must be used for all loader operations.

Maintenance And Inspection

Inspect for worn or loose parts regularly. Lubricate according to specifications in this manual. Never alter or modify any part of the mounting brackets, loader or attachments. Doing so can result in an unsafe condition and may void the warranty.

SECTION 2: SAFETY

Prepare For Emergencies

Be prepared in case of an emergency.

Keep a fire extinguisher and first aid kit handy.

Keep emergency phone numbers close to your phone.

Know your address so emergency services can locate you if an emergency arises.

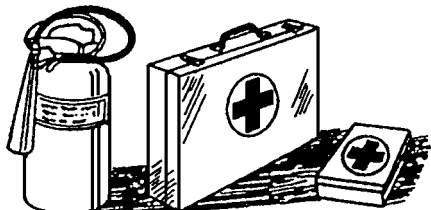

Do Not Allow Riders

NEVER lift or carry anyone with the loader, bucket or attachments.

NEVER use the loader or attachment as a work platform.

NEVER allow passengers on the tractor. Be sure that people, livestock and pets are clear of machinery while operating.

DO NOT lift or carry anyone with the loader, bucket or attachment.

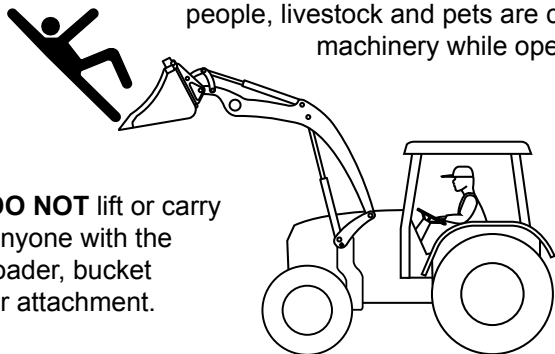

High Lift Loaders

High lift loader require tractors with a long wheel base. The rear wheels need to be set out all the way or preferably dual rear wheels and adequate ballast. (See ballast calculations in your loader's operator manual.)

The front wheels are the fulcrum when raising a load. You must have sufficient leverage and ballast to offset the loader in front of the front tires.

Extreme care and slow speed must be used when raising and dumping a load. Monitor the load at all times.

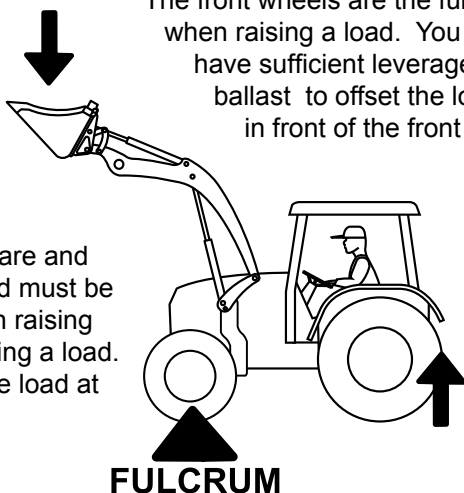

Avoid Rollover

Your tractor may rollover, resulting in death or serious injury. **To avoid rollover:**

- Travel at a slow speed;
- Carry loads close to the ground;
- Avoid sharp turns and sudden movements on slopes;
- Avoid holes, ditches and other obstructions which may cause the tractor to rollover;
- Balance load so weight is evenly distributed and load is stable;
- Be extra careful when operating on slopes and do not operate on excessively steep slopes;
- Do not exceed the load capacity of your equipment;
- Be certain tractor tire spacing and rear ballast are correct before using equipment;
- Approach large round or square bales on a slope with the tractor facing uphill.

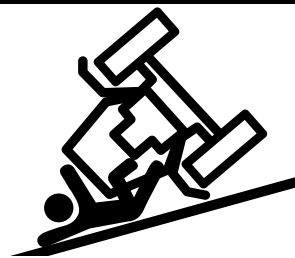

Avoid Power Lines & Underground Utilities

Death or serious injury can result if equipment comes near or contacts power lines.

Electrocution can occur without direct contact.

Check clearance before raising equipment.

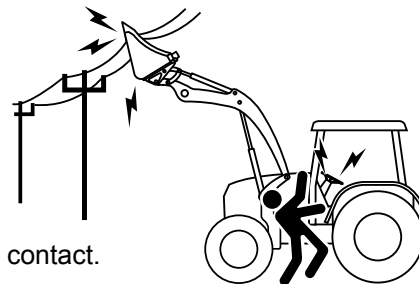

Have local utilities locate and mark under ground wires, cables, pipelines and other hazards before digging.

DO NOT leave the operator's seat if any part of the equipment contacts electric lines or cables.

Lower Operating Speed

Lower your operating speed while digging, loading or performing heavy operations.

Move at slow speeds on rough or uneven terrain while keeping the load low.

Replace Safety Signs

Replace missing or damaged safety signs.

Safety signs & part no. locations are identified in this manual.

Replacement safety signs are available from your Westendorf dealer at no cost.

SECTION 2: SAFETY

Prevent Falling Loads

ALWAYS secure the load at the source.

Round bales, square bales, posts, stones, logs, and other objects can fall or roll from a raised loader or attachment, which may crush the operator or bystanders.

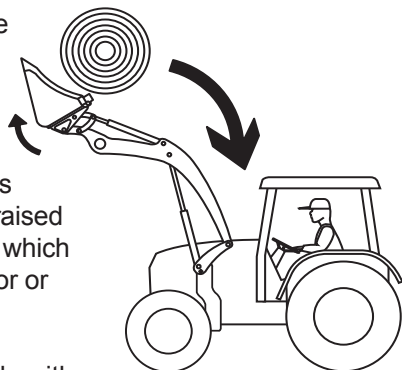

Handle all raised loads with caution. Keep eyes on load while raising or lowering.

- **DO NOT** carry items that may shift in the loader bucket or attachment.
- **DO NOT** handle round or square bales unless the loader is equipped with the proper bale handling attachment.
- **DO NOT** handle bales with the pallet fork attachment.
- **NEVER** travel with a raised load.
- **ALWAYS** carry loads low and close to the ground.

Transport Loads Safely

Use the proper attachment to lift and carry the load.

Follow the instructions in the appropriate operator's manual for any loader attachments.

Carry loads low and slightly rolled back.

Travel **SLOW** and avoid slopes.

Raised Loader

A raised loader can fall unexpectedly, resulting in death or serious injury.

NEVER enter the area under a raised loader or attachments.

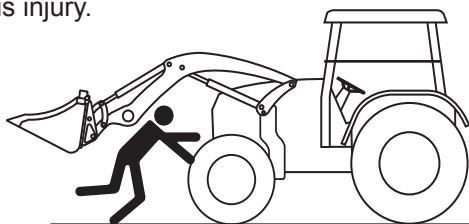

Lower bucket or attachments to the ground, place tractor transmission in park, shut off engine and remove key before servicing loader or attachments.

Detach loader from tractor to service the tractor.

Avoid High Pressure Fluids

Escaping fluid under pressure can penetrate the skin causing serious injury.



Avoid the hazard by relieving pressure before connecting or disconnecting hydraulic lines. Tighten all connections before applying pressure.

Search for leaks with a piece of cardboard or wood. Protect hands and body from high pressure fluids.

If an accident occurs, see a doctor immediately. Any fluid injected into the skin must be surgically removed within a few hours or serious infection may result. Doctors unfamiliar with this type of injury should reference a knowledgeable medical source.

DO NOT mount a valve with direct mount joystick inside the tractor cab. Use only a remote cable inside cab.

Hydraulic Control Functions

Check the loader response to the control lever movement. The loader should respond according to the ASAE standards shown. If response is incorrect, check the hydraulic hose connections at the tractor and manifold and correct if necessary. 1-Lever control functions will be shown throughout the manual, refer back to this section for operation regarding the 2-Lever control.

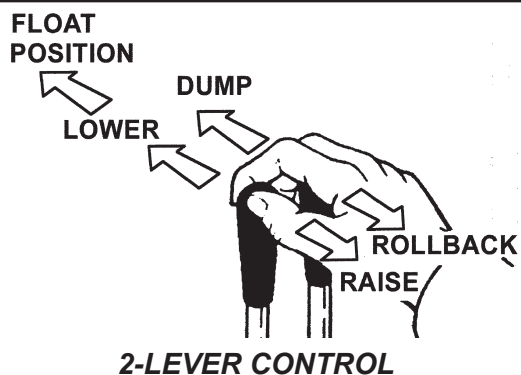
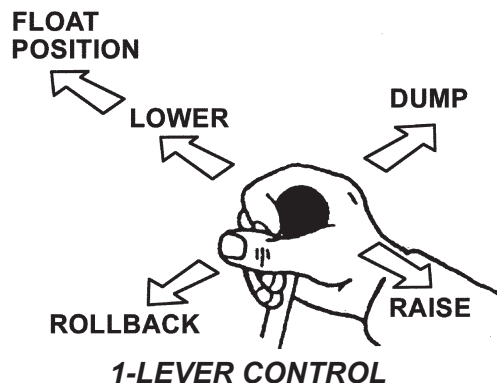

ASAE standard S335.4 shown in above illustrations

SECTION 2: SAFETY

This engineering practice is intended as a guide to determine the minimum ballast and tread settings recommended for the operation of a front loader mounted on a 2WD tractor or a tractor with front assist. These ballast and tread setting recommendations are intended to reduce the risk of vehicle over-turn during typical operation.

BALLAST refers to cast weights or fluid added to rear tractor tires. Hitch ballast refers to a weight or an implement attached to the tractor three-point hitch.

GROSS VEHICLE WEIGHT (GVW) is the sum of front and rear axle weight caused by the mass of the tractor, loader, attachment, payload, ballast and hitch ballast.

Determination of Ballast

WARNING CRUSHING HAZARD.

To prevent personal injury or death from tractor loader roll-over, add the recommended amount of ballast to the tractor. Always use a ROPS and wear a seatbelt.

The operational ballast criterion has been met when a minimum of 25% of the gross vehicle weight is retained on the rear axle in a static condition on level ground.

- A mass equivalent to the Lift Capacity maximum height should be placed in the loader bucket, with the boom raised until the bucket pivot pin is the same distance from the ground as the boom pivot (farthest forward position). The rear axle weight and gross vehicle weight should be measured on hard level ground ($\pm 1^\circ$) under these conditions. See Figure 1.

- Ballast must be added to the rear wheels and/or hitch

NOTICE TRACTOR DAMAGE.

To avoid tractor damage use hitch ballast. Failure to use ballast can cause the front axle or other tractor components to be overloaded during loader operation.

until the rear axle weight on level ground is a minimum of 25% of the gross vehicle weight. Ballast added to the rear hitch should be kept as low as practical.

- When a loader is used in a dedicated situation, an operator may determine the appropriate ballast, based on the maximum load to be carried.
- We recommend ballast, based on the criteria listed in above and knowledge of the physical characteristics of the tractor.

Types of Ballast

Lift Capacity to Max Height

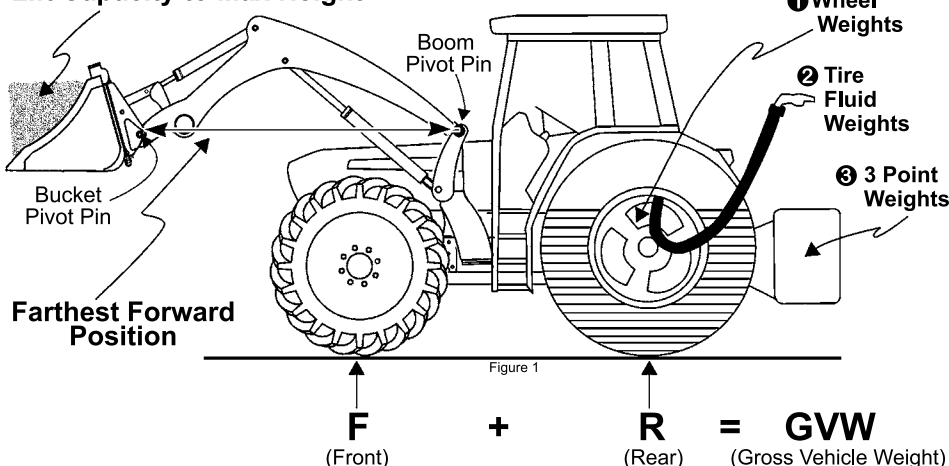

Three Simple Steps

STEP 1: Put weight in the bucket equivalent to the lift capacity of the loader at full lift height. The lift capacity can be found in several locations:

- Operators manual
- Company Literature
- Visit us online at www.loaders.com
- Or Call Us at 712-423-2762

STEP 2: At the scale get the gross vehicle weight (GVW) with the loader raised so the bucket pivot pin is as high as the boom pivot pin. See Figure 1. Then weigh the rear axle (R).

STEP 3: Formulas to figure ballast.

$$GVW \times 25\% = \text{Required Rear Axle Weight (RRAW)}$$

< IS LESS THAN > IS GREATER THAN

If $R > RRAW = \text{No Ballast Required}$
If $R < RRAW = \text{Ballast Required}$

Figure Rear Ballast Required (RBR):

$$RRAW - R = RBR$$

$$RBR \times 133\% = \text{Ballast Required}$$

Note: Since adding ballast increases the total weight adding the difference will not be enough. You need to add approximately 133% of the difference. Depending on where you add the ballast in respect to the rear axle the amount of weight may vary.

Glossary of Terms

GVW = Gross Vehical Weight
F = Front Axle Weight
R = Rear Axle Weight
RRAW = Required Rear Axle Weight
RBR = Rear Ballast Required
< is Less than and > is Greater than

Minimum Tread Settings

The rear wheel width is the most important specification to the balance of your tractor loader operation.

Always use approved ROPS and fasten your seat belt.

Minimum tread settings are recommended to provide static stability on a side slope up to 15 degrees under proper rear ballast conditions listed in above. If minimum tread settings are not available in your mounting instructions, minimum rear tread settings should be selected from the following chart:

TRACTOR MASS		MINIMUM REAR TREAD SETTING		
Kg	Lbs	mm	in.	(A)
<2250	<4950	1575	62.0	
2250-3650	4950-8030	1675	65.9	
>3650	>8030	1825	71.8	

Note: These tread settings are recommended for a standard tractor configuration. A tractor with a high center of gravity or an unusual configuration may require a wider minimum tread setting to achieve the same level of stability.

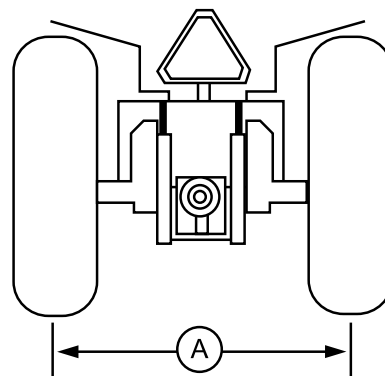

Figure 2 - Rear Tread Setting

This information refers to ASAE S301.3, Front-End Agricultural Loader Ratings and ASAE S390.3, Definitions and Classifications of Agricultural Field Equipment, to EN12525:2000 Agricultural machinery - Front Loaders - Safety.

SECTION 2: SAFETY

Round Bale Safety

Handle all raised loads with caution. Keep eyes on load while lowering or raising to help prevent personal injury or death caused by falling or crushing loads:

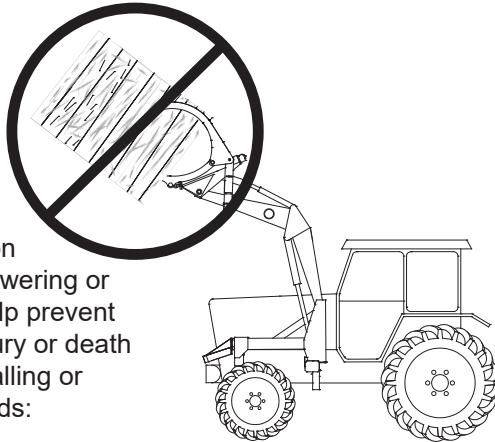

- **DO NOT** handle round or square bales unless the loader is equipped with an approved bale handling attachment.
- Brush Crusher is **NOT** designed for handling hay.
- **NEVER** travel with a raised load.
- **ALWAYS** carry loads low and drive slow.

Lockout valve detents to prevent automatic loader movement (See tractor's owners manual).

Balance Uneven Loads Properly

Due to the nature of trees and limbs being heavier on one end than the other, use extra caution when handling uneven loads.

- **DO** center the weight of the uneven load in your attachment.
- **AVOID** twisting loads.
- **ALWAYS** carry loads low and drive slow.
- **ALWAYS** be alert of your surrounding when carrying loads.

Handling Your Brush Crusher™

To help prevent personal injury, do not attempt to pick up the attachment by yourself. Use a mechanical device or team lift when handling the attachment. Use extreme caution when moving and handling this attachment. When not properly secured the teeth assemblies will swing together and could cause personal injury.

Using Your Brush Crusher™ & Safety Decal Locations

We have given you the Cautions, Warnings, and Dangers that we could foresee, however due to the flexibility of the product there are uses not thought of yet. Please use common sense and good judgment when operating these units. ***If it does not appear to be safe, it isn't.***

Prior to actual work, operate the unit to get an idea of how it works. New operators should read the operator's manual.



SAFETY DECAL LOCATION

These decals are located on the loader and attachments. If any decals become damaged or illegible you can order replacements, free of charge, by writing to:

Westendorf Mfg. Co., Inc.
PO Box 29
Onawa, IA 51040-0029

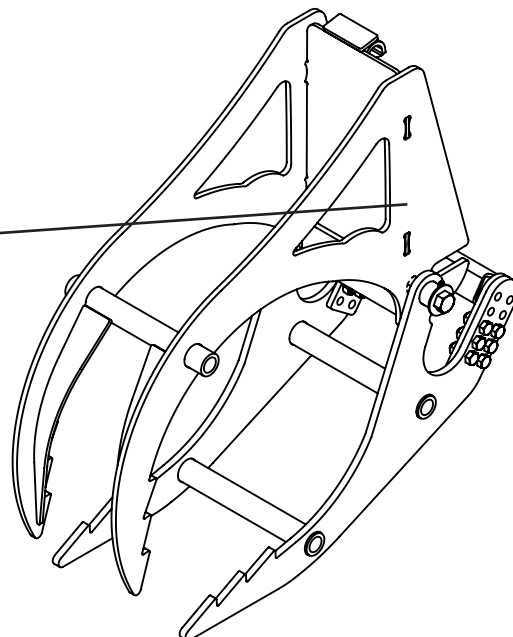

SECTION 3: MOUNTING / DISMOUNTING**Mounting and Dismounting**

1. To mount, hook the coupler underneath the upper lip (A) on the Brush Crusher™ and roll back the bucket cylinder.

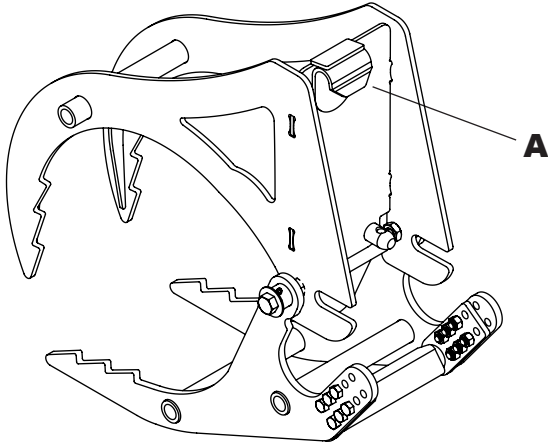

2. Secure at the bottom with the lynch pin from your coupler.
3. To dismount, remove lynch pin, roll the bucket cylinder forward and slide the couplers out from underneath the lip (A).

SECTION 4: OPERATION

The Mechanical Advantage

The Westendorf Brush Crusher is a unique product, take time to understand how it operates. The mechanical advantage allows you to use the bucket cylinders to operate the teeth, saving you the expense of added hydraulics. The Brush Crusher is a very powerful tool, please review the following tips when operating this unit.

Approaching the Load

Approaching the load will vary based on the loader and Brush Crusher model you have. Pay particular attention to the teeth when they are in the open position. Whichever set of teeth are closer to the ground determines how to approach the load. Position the claw around the object by lowering your loader arms and driving into (Figure 1) or away from the object. Draw the object into the claws by closing the teeth and lowering the arms.

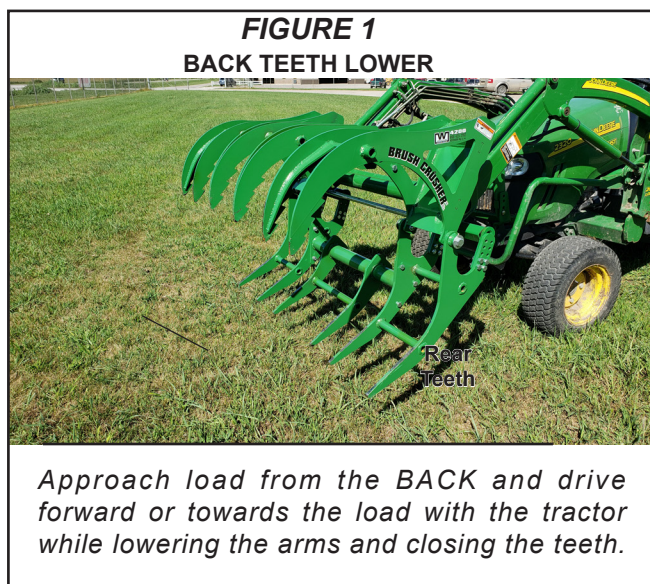

NOTICE

CRUSHING HAZARD.

To prevent tractor or equipment damage:

- Know the limitations of your equipment.
- DO NOT exceed the capacity that your loader or Brush Crusher™ can handle safely.
- Center the weight of the load in the attachment.
- Avoid twisting loads.
- See your tractor operator's manual for ballast and tire setting recommendations.



The teeth can open or close independently of each other based on the amount of hydraulic resistance when center bar/teeth are removed.



At times you may want to put the loader into FLOAT when closing the teeth. This allows the Brush Crusher to adjust or capture the load.

SECTION 5: SERVICE & MAINTENANCE

Maintenance Checklist

Perform scheduled maintenance as outlined below.

1. Lower the bucket or attachment to the ground, or remove on level surface to perform maintenance.
2. Turn off tractor engine, remove key, and set tractor parking brake before performing inspections.

⚠ WARNING CRUSHING HAZARD.

To prevent automatic movement:

- Operate loader from the operator's seat only.
- Remain at the controls until the operation cycle is fully complete.
- Lock-out valve "detent" when operating loader. See your tractor operator's manual.

3. Relieve hydraulic pressure. Use wood or cardboard to inspect hydraulic hoses, lines and fittings for damage, wear and leaks. Repair or replace as necessary.

4. Inspect pivot pins for wear. Be certain retaining roll pins are installed on each pin.

5. Check all mounting hardware for tightness. Use the torque charts in this section.

6. Lubricate BC-4200 grease fittings as shown below.

7. While in use, listen for abnormal or unusual sounds that may indicate worn, loose or damaged parts.

8. After each use, clean loader and verify all safety decals are legible and not damaged. Replace damaged safety decals.

Lubrication

Grease all zerks noted below every 10-12 hours. Failure to grease the loader may result in premature wear. All zerks can be accessed with the loader on tractor, arms down and the attachment level.

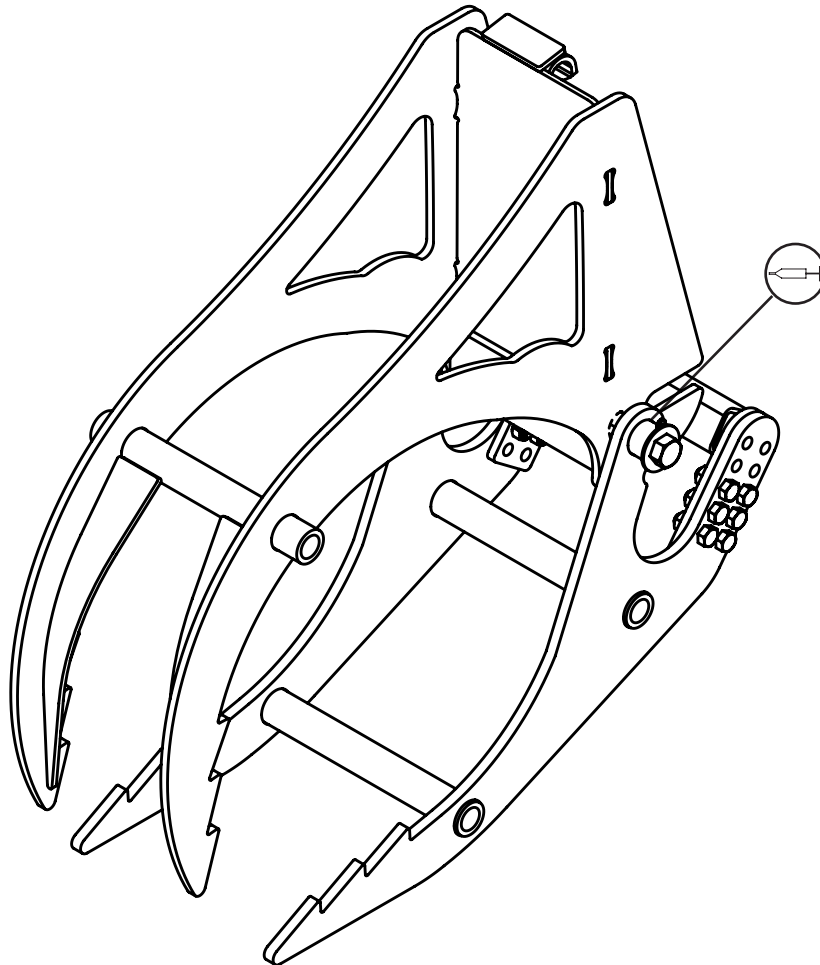

SECTION 5: SERVICE & MAINTENANCE

Torque Chart

1. ALWAYS tighten hardware to these values unless a different torque value or tightening procedure is listed for a specific application.

2. Fasteners MUST always be replaced with the same grade as specified in the manual parts list.

3. Always use proper tools for tightening hardware. SAE for SAE hardware and Metric for Metric hardware.

4. Make sure fastener threads are clean and you start thread engagement properly.

5. All torque values are given to specifications used on hardware defined by SAE J1701 & J1701M.

"Lubricated" means coated with a lubricant such as engine oil, fasteners with phosphate and oil coatings.

"Dry" means plain or zinc plated without any lubrication.

Bolt Size	SAE Torque-Tension Values					
	Grade 2		Grade 5		Grade 8	
	DRY lb-ft (N•m)	LUBRICATED lb-ft (N•m)	DRY lb-ft (N•m)	LUBRICATED lb-ft (N•m)	DRY lb-ft (N•m)	LUBRICATED lb-ft (N•m)
1/4-28	6 (9)	5 (6)	10 (14)	7 (10)	14 (19)	10 (14)
1/4-20	6 (9)	4 (5)	8 (11)	6 (9)	12 (16)	9 (13)
5/16-24	13 (18)	9 (13)	19 (26)	14 (19)	27 (36)	20 (27)
5/16-18	11 (15)	8 (11)	17 (23)	13 (18)	25 (33)	18 (25)
3/8-24	23 (31)	17 (23)	35 (47)	26 (35)	49 (67)	37 (50)
3/8-16	20 (27)	15 (20)	31 (42)	23 (31)	44 (59)	33 (44)
7/16-20	36 (48)	27 (36)	55 (75)	41 (56)	78 (106)	58 (79)
7/16-14	32 (43)	25 (33)	49 (67)	37 (50)	70 (95)	52 (71)
1/2-20	55 (75)	41 (56)	85 (115)	64 (86)	120 (163)	90 (122)
1/2-13	49 (67)	37 (50)	75 (100)	57 (77)	106 (144)	80 (108)
9/16-18	78 (106)	59 (80)	121 (164)	91 (123)	171 (232)	128 (174)
9/16-12	70 (95)	53 (72)	109 (148)	82 (111)	154 (209)	115 (156)
5/8-18	110 (149)	82 (111)	170 (231)	127 (172)	240 (325)	180 (244)
5/8-11	97 (132)	73 (99)	150 (204)	113 (153)	212 (287)	159 (216)
3/4-16	192 (260)	144 (195)	297 (403)	223 (302)	420 (569)	315 (427)
3/4-10	172 (233)	129 (175)	269 (365)	201 (273)	376 (510)	282 (382)
1-12			704 (954)	528 (716)	995 (1350)	746 (1010)
1-8			644 (873)	483 (655)	909 (1230)	681 (923)

Metric Torque-Tension Values

Bolt Size	Metric Torque-Tension Values							
	Class 4.8		Class 8.8		Class 10.9		Class 12.9	
	DRY lb-ft (N•m)	LUBRICATED lb-ft (N•m)	DRY lb-ft (N•m)	LUBRICATED lb-ft (N•m)	DRY lb-ft (N•m)	LUBRICATED lb-ft (N•m)	DRY lb-ft (N•m)	LUBRICATED lb-ft (N•m)
M6	4.7 (3.5)	6 (4.5)	8.9 (6.5)	11.3 (8.5)	13 (9.5)	16.5 (12)	15.5 (11.5)	19.5 (14.5)
M8	11.5 (8.5)	14.5 (10.5)	22 (16)	27.5 (20)	32 (23.5)	40 (29.5)	37 (27.5)	47 (35)
M10	23 (17)	29 (21)	43 (32)	55 (40)	63 (46)	80 (59)	75 (55)	95 (70)
M12	40 (29.5)	50 (37)	75 (55)	95 (70)	110 (80)	140 (105)	130 (95)	165 (120)
M14	63 (46)	80 (59)	120 (88)	150 (110)	175 (130)	220 (165)	205 (150)	260 (190)
M16	100 (74)	125 (92)	190 (140)	240 (175)	275 (200)	350 (255)	320 (235)	400 (300)
M18	135 (100)	170 (125)	265 (195)	330 (245)	375 (275)	475 (350)	440 (325)	560 (410)
M20	190 (140)	245 (180)	375 (275)	475 (350)	530 (390)	675 (500)	625 (460)	790 (580)
M22	265 (195)	330 (245)	510 (375)	650 (480)	725 (535)	920 (680)	850 (625)	1080 (800)
M24	330 (245)	425 (315)	650 (480)	820 (600)	920 (680)	1150 (850)	1080 (800)	1350 (1000)

SECTION 5: SERVICE & MAINTENANCE

Service & Maintenance

BC-4200 Basic Parts

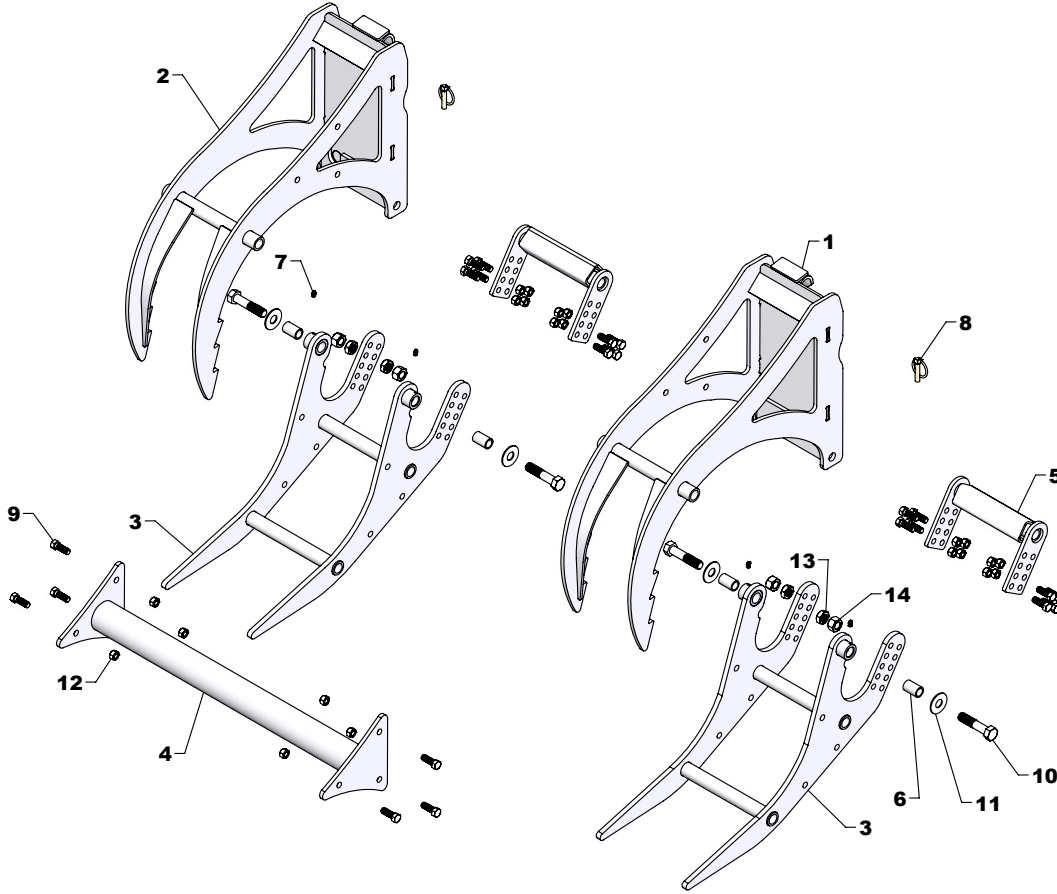

BC-4200 BRUSH CRUSHER™ REPLACEMENT PARTS

REF #	PART #	DESCRIPTION	QTY
1	BCP-360AS - L	UPPER TOOTH (LEFT)	1
2	BCP-360AS - R	UPPER TOOTH (RIGHT)	1
3	BCP-361AS	LOWER TOOTH	2
4	BCP-373AS	SYNCHRONIZER BAR	1
5	BCP-368AS	ARM STOP	2
6	BCP-371	INSERT BUSHING	4
7	ZER1805	GREASE FITTING	4
8	QLP0700024	LYNCH PIN	2

REF #	PART #	DESCRIPTION	QTY
9	HHS0813024	1/2" X 1 1/2" BOLT	22
10	HHS1210056	3/4" X 3 1/2" BOLT	4
11	FWW12	3/4" FLAT WASHER	4
12	HTN0813	1/2" LOCK NUT	22
13	TSN1210	3/4" THIN ELASTIC STOP NUT	4
14	HFN1210	3/4" NUT	4
*	DE-BC-4200	DECAL KIT (NOT SHOWN)	1

WESTENDORFMFG RTS918121

WESTENDORF MFG CO., INC. • PH: (712) 423-2762 • FAX: (712) 423-1460 • sales@westendorfmfg.com • www.loaders.com

SECTION 5: SERVICE & MAINTENANCE

Service & Maintenance

BC-4200 Brush Crusher™ Kits

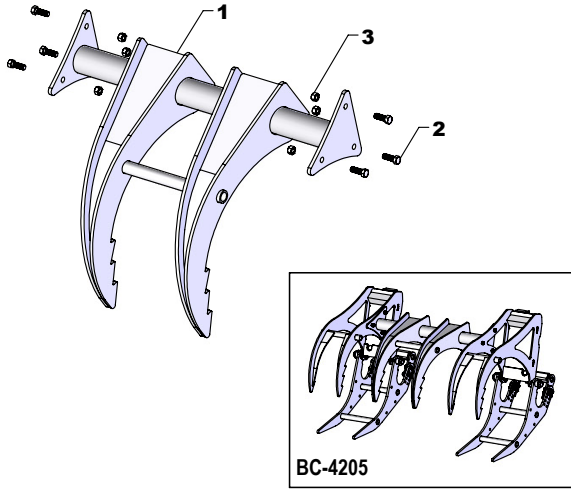

BC-0005 TOP TEETH KIT

REF #	PART #	DESCRIPTION	QTY
1	BCP-386AS	TOP TEETH ASSEMBLY	1
2	HHS0813024	1/2" X 1 1/2" BOLT	6
3	HTN0813	1/2" LOCK NUT	6
4	BC-4205	BRUSH CRUSHER	1

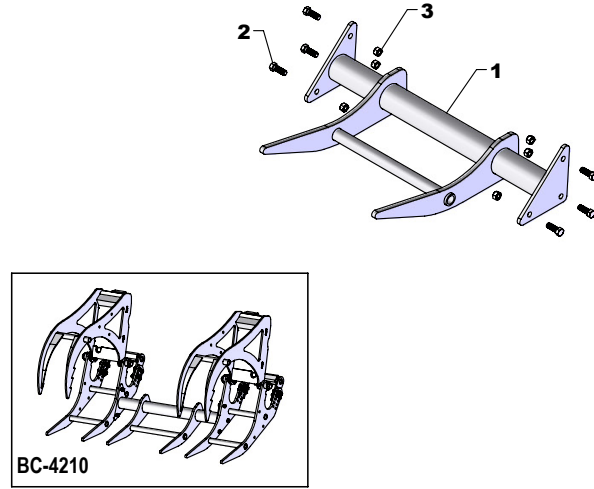

BC-0010 BOTTOM TEETH KIT

REF #	PART #	DESCRIPTION	QTY
1	BCP-388AS	BOTTOM TEETH ASSEMBLY	1
2	HHS0813024	1/2" X 1 1/2" BOLT	6
3	HTN0813	1/2" LOCK NUT	6
4	BC-4210	BRUSH CRUSHER	1

BC-0015 TOP & BOTTOM TEETH KIT

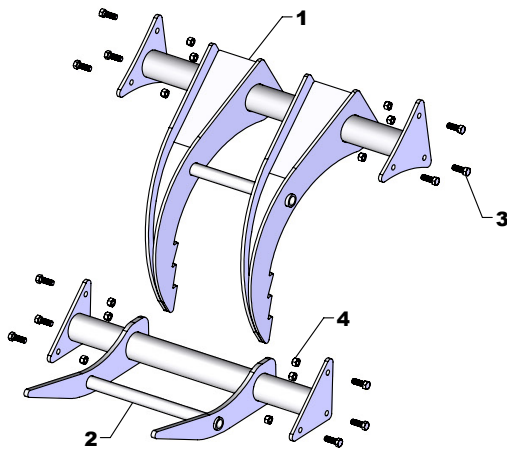

REF #	PART #	DESCRIPTION	QTY
1	BCP-386AS	TOP TEETH ASSEMBLY	1
2	BCP-388AS	BOTTOM TEETH ASSEMBLY	1
3	HHS0813024	1/2" X 1 1/2" BOLT	12
4	HTN0813	1/2" LOCK NUT	12
5	BC-4215	BRUSH CRUSHER	1

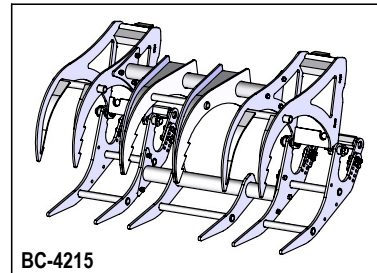

WESTENDORFMFG RTS918121

WESTENDORF MFG. CO., INC. • PH: (712) 423-2762 • FAX: (712) 423-1460 • sales@westendorfmfg.com • www.loaders.com

ASSEMBLY INSTRUCTIONS

BC-4200

DR. BY: STR

DATE: 12/18/19

RN: 0

DATE: 7/12/17

BY: BWP

PAGE: 3 OF 4

REF #	DESCRIPTION	QTY.
1	LOWER TOOTH	1
2	ARM STOP	1

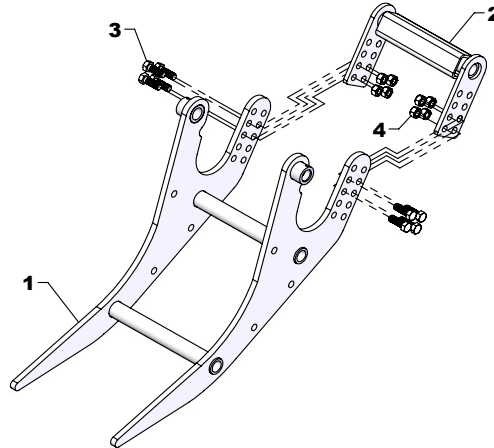

ILLUSTRATION SHOWS ONE SIDE; REPEAT FOR OTHER SIDE

A) Attach the arm stop to the lower tooth, as shown.

NOTE: Adjust the arm stop to achieve the least amount of stress when closed and clearance of your loader model.

REF #	DESCRIPTION	QTY.
3	1/2" X 1 1/2" BOLT	8
4	1/2" LOCK NUT	8

REF #	DESCRIPTION	QTY.
1	UPPER TOOTH (LEFT)	1
2	LOWER TOOTH	1
3	INSERT BUSHING	2
4	LYNCH PIN	1
5	GREASE FITTING	2

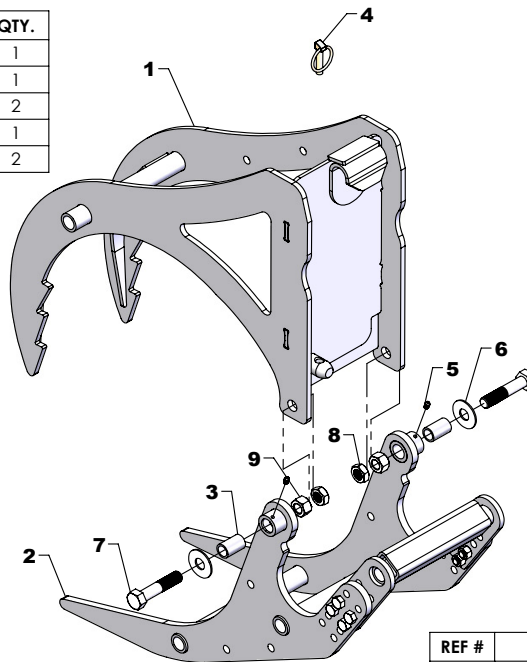

ILLUSTRATION SHOWS ONE SIDE; REPEAT FOR OTHER SIDE

A) Attach the upper teeth to the lower teeth, as shown.

REF #	DESCRIPTION	QTY.
6	3/4" FLAT WASHER	2
7	3/4" X 3 1/2" BOLT	2
8	3/4" THIN ELASTIC STOP NUT	2
9	3/4" NUT	2

ASSEMBLY INSTRUCTIONS

BC-4200

DR. BY: STR

DATE: 12/18/19

RN: 0

DATE: 7/12/17

BY: BWP

PAGE: 4 OF 4

REF #	DESCRIPTION	QTY.
1	UPPER TOOTH (LEFT)	1
2	UPPER TOOTH (RIGHT)	1
3	SYNCHRONIZER BAR	1

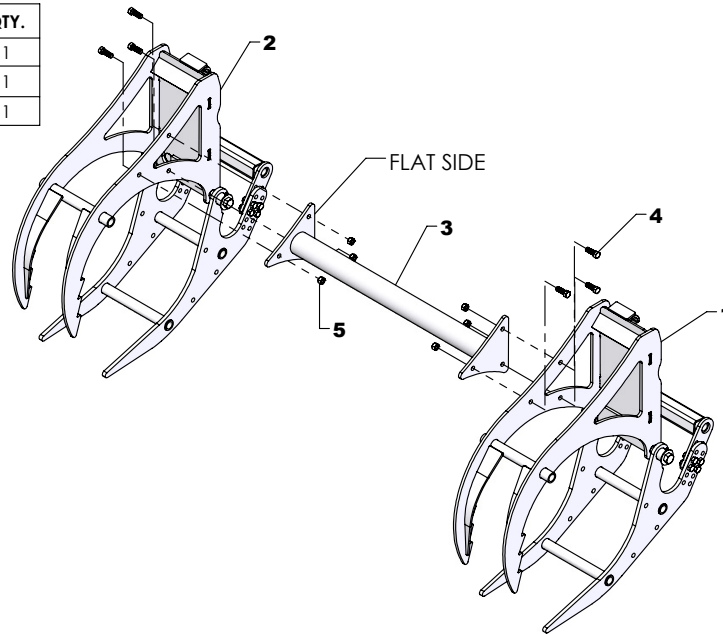

ILLUSTRATION SHOWS BOTH SIDES

A) Attach the synchronizer bar to the upper teeth, as shown.

NOTE: To get the holes lined up, the flat side of the plate on the synchronizer bar must be towards the loader side of the brush crusher and must be orientated correctly right to left, as shown.

REF #	DESCRIPTION	QTY.
4	1/2" X 1 1/2" BOLT	6
5	1/2" LOCK NUT	6

MOUNTING COMPLETE

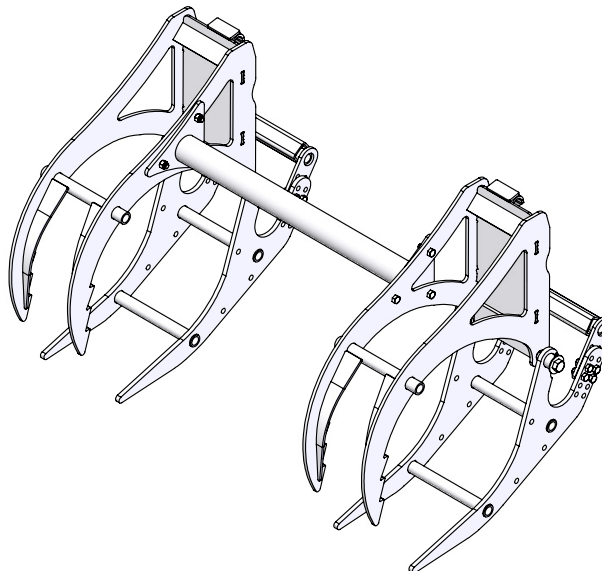

NOTE: CHECK AND TIGHTEN ALL NUTS AND BOLTS

SECTION 5: SERVICE & MAINTENANCE

Preparing the Brush Crusher™ for Storage

- Replace damaged or missing parts including pins, hardware and decals.
- Clean the Brush Crusher thoroughly. Dirt attracts moisture which causes rust.
- Lubricate all grease fittings.
- Paint the loader or attachment when needed.

Storing the Brush Crusher™

- Store attachments inside, if possible, on a solid, level surface, as shown. If stored outside, cover the unit with a waterproof material.
- Store Brush Crusher units out of way so they do not have to be moved between uses.

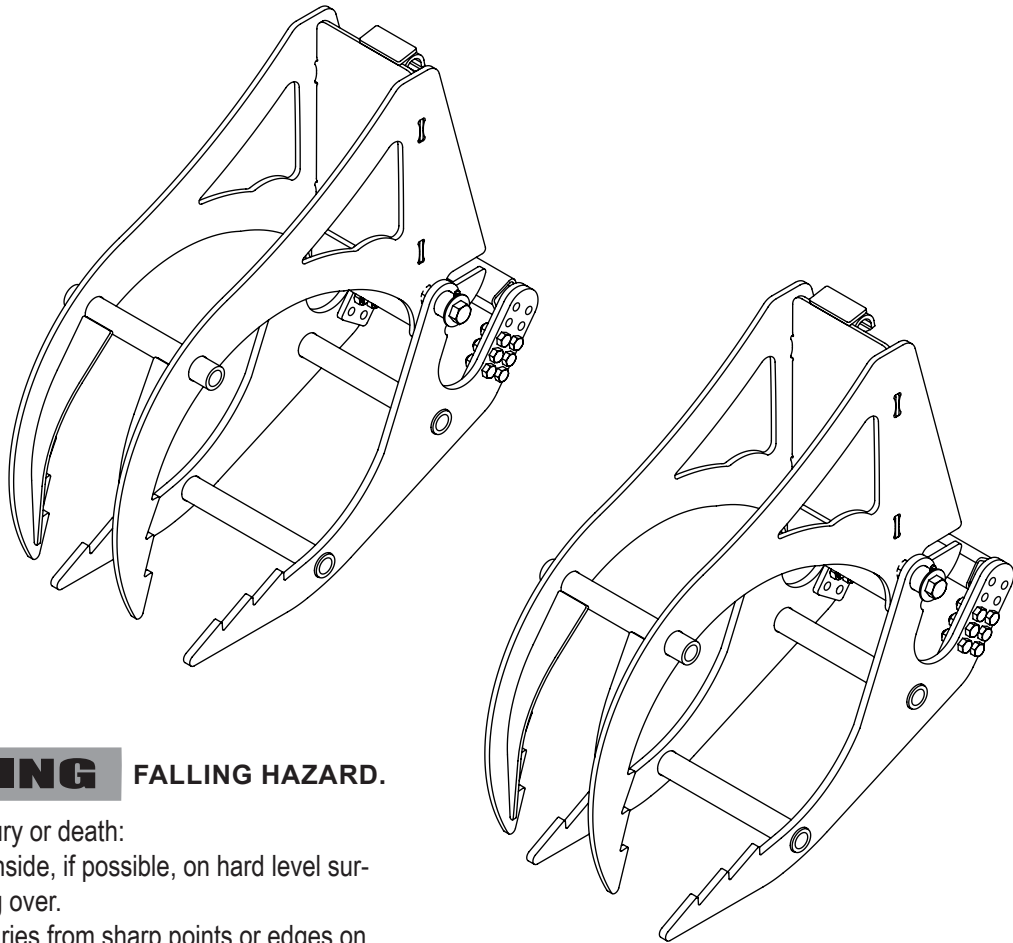

⚠ WARNING FALLING HAZARD.

To prevent serious injury or death:

- Store attachment inside, if possible, on hard level surface to avoid falling over.
- Protect against injuries from sharp points or edges on attachment.
- Keep children and bystanders away from storage area.



WESTENDORF



Exclusive Patented Features:

- Power-Mount™ - Mount & dismount loader hydraulically in One Step without tools or dangerous stands.
- Snap-Attach™ - The original quick change system that automatically locks attachments in place.
- Hydra-Snap™ - a single lever manifold that couples all the hoses in one smooth motion.
- Uni-Fit™ Brackets- Custom adjust the loader to fit your tractor for low-profile fit and smooth operation.

Your One Stop Shop For Material Handling Solutions

- Loaders
- Buckets
- Bucket Accessories
- Tine Bucket
- Fork Bucket
- Quick-Mount Grab Forks
- Cat Claw 3D Grab Forks
- Bale Spears
- Stack Saver® I & II
- Bale Grab
- Squeezer
- Bale Handler
- Brush Crushers™
- V-Plow
- Dozer Blades
- Forklifts
- 3-Point Attachments
- Auto-Dump™
- Dual Tire Changer
- Landscaper™
- Hitch-N-Go™
- Lowboy Trailer
- Anhydrous Wagon™
- Running Gears
- Wagon Packages
- Cool Cap™ Canopy
- Dump Spreader
- More online at....

www.loaders.com